

DETAIL A
SCALE 6 : 1

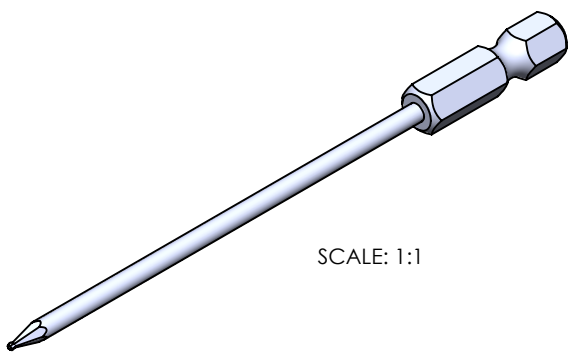

SCALE: 1:1

UNLESS OTHERWISE SPECIFIED: DIMENSIONS ARE IN INCHES				TOLERANCES: X.XX= ±0.13 X.XXX= ±0.015 X.XXXX= -0.0015	
DRAWN	NAME	SIGN	DATE		
APPVD	A.T.		09.03.19		

MATERIAL:
SHAFT: 465 MAGNETIC S.S.
POWER HEX BIT: 316 NON-MAGNETIC S.S.

THIS DRAWING IS THE PROPERTY OF STERITOOl, INC. ANY REPRODUCTIONS OR MODIFICATIONS OF THIS DRAWING OR ITS CONTENTS WITHOUT THE CONSENT OF STERITOOl, INC. IS PROHIBITED.

STERITOOl™
The Global Source for Stainless Steel Tools

TITLE:
0.035" BALL HEX X 4.00" OAL, 1/4" POWER HEX BIT

PART NO.	13020	REV:	A
SCALE: 2:1	SHEET 1 OF 1		